

## 15W OYSTER LIGHT (PLAIN)

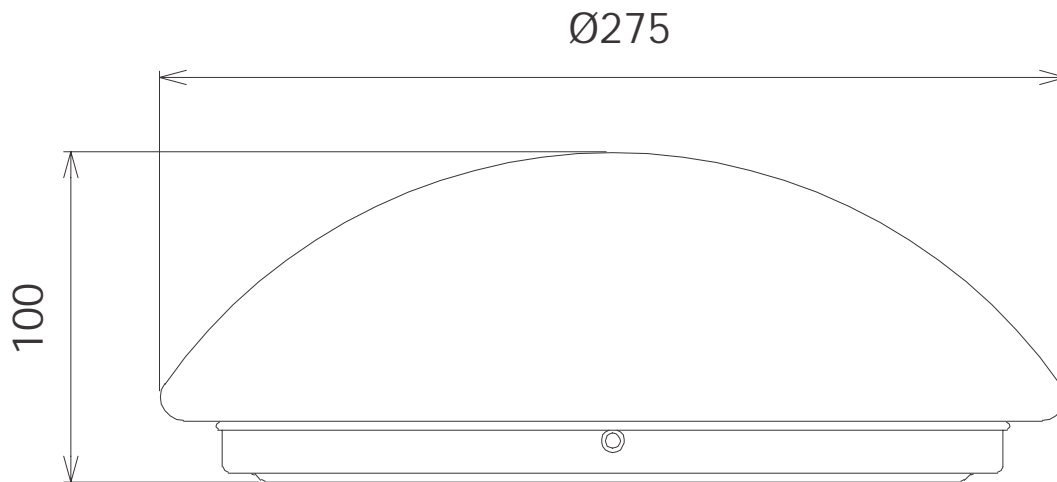

15W LED OYSTER DATA SHEET (PLAIN)

## Introduction



LED Lighting 15W-Plain Oyster light integrates 5630SMD light source and a compact high efficient driver into a traditional CFL replacement. It employs a high-tech IC solution to ensure good stability and dimming system control. With easy installation, and the simple graceful design, the ceiling light is directly installed on the ceiling and use as main lighting fixtures for indoors.

Up to 70% energy saving compared to standard CFL

Long lifetime of 40,000 hours

Dimmable when using triac dimmer

120° wide beam angle

CCT: 3000K-3200K 4000K-4500K

5000K-5500K 5500K-6000K

No UV/IR light

Environment friendly, without Mercury or any other hazardous substances

### **Application notes**

IP20 for indoor use only

The lamp must be installed by professional electrician

Ensure the power supply is switched off before fitting this product

Do not touch the lamp when in use

Keep away from hot steam and corrosive gas

### **Application Areas**

LED Lighting 15W-Plain Oyster light is designed for general lighting applications in hotel, home, office, shop etc. It is also widely used for public areas such as stairway, lobby, reception, corridors etc.

### **Certificates**



## Product Information

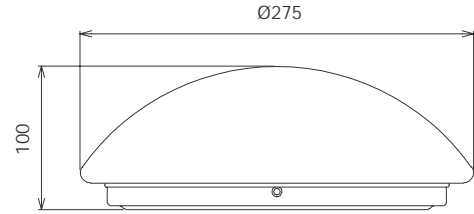

### Technical Specifications

Model	Voltage	Power	Power Factor	Lumen (±5%)	Beam angle	CCT	Lifespan	CRI	Dimmable	Dimension
OYSTER-P-15W	AC100-240V	15W	≥0.9	1050	120°	3000K	40000hs	≥80		
OYSTER-P-15W	AC100-240V	15W	≥0.9	1170	120°	4000K	40000hs	≥80		
OYSTER-P-15W	AC100-240V	15W	≥0.9	1220	120°	5000K	40000hs	≥80		
OYSTER-P-15W	AC100-240V	15W	≥0.9	1240	120°	5700K	40000hs	≥80		
OYSTER-P-15W-DIM	AC100-130V AC200-240V	15W	≥0.9	1000	120°	3000K	40000hs	≥80	Yes	
OYSTER-P-15W-DIM	AC100-130V AC200-240V	15W	≥0.9	1100	120°	4000K	40000hs	≥80	Yes	
OYSTER-P-15W-DIM	AC100-130V AC200-240V	15W	≥0.9	1160	120°	5000K	40000hs	≥80	Yes	
OYSTER-P-15W-DIM	AC100-130V AC200-240V	15W	≥0.9	1180	120°	5700K	40000hs	≥80	Yes	Ø275*100mm

### Driver data Sheet

Driver data	DIM	DIM	Non-dim
Input Voltage	AC100-130V	AC200-240V	AC100-240V
Frequency	60Hz	50Hz	50-60Hz
Input rated Voltage	AC110V	AC230V	AC100-240V
Efficiency	≥78%	≥78%	≥85%
No load wattage	≤0.8W	≤0.8W	≤0.7W
Total load Wattage	15W±1W	15W±1W	15W±1W
Power Factor	≥0.9	≥0.9	≥0.9
Rated input current	≤0.15A	≤0.08A	≤0.15A
No load output Voltage	DC39V	DC39V	DC49V
No load output Voltage range	DC37-42V	DC37-42V	DC46-52V
Full load output Voltage	DC26-30V	DC26-30V	DC26-30V
Rated output current	350mA	350mA	380mA
Output current range	340mA-360mA	340mA-360mA	370mA-390mA
Tolerance	±5%	±5%	±5%
Current output tolerance	±5%	±5%	±5%
Dimming range	8%-100%	8%-100%	—
Dimmer	Triac dimmers	Triac dimmers	—
Withstand voltage	AC3750V	AC3750V	AC3750V

### Fixture Compatibility

Rated Wattage	Electrical Classification	Ingress Protection (IP)	Operating Temp	Operating Humidity	Storage Temp
15W	II	20	-10°C-45°C	0-90%	-20°C-65°C

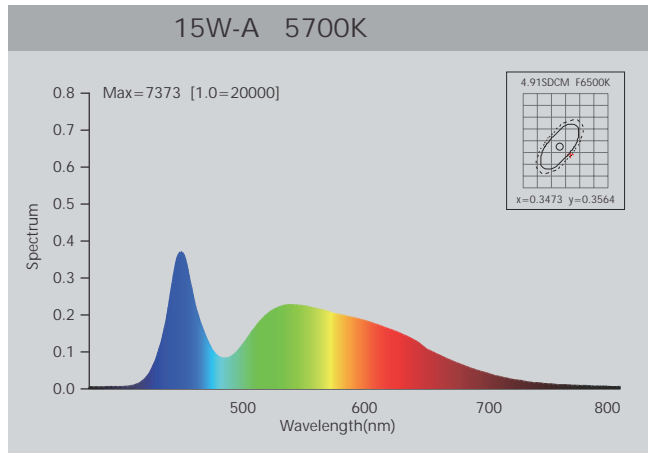
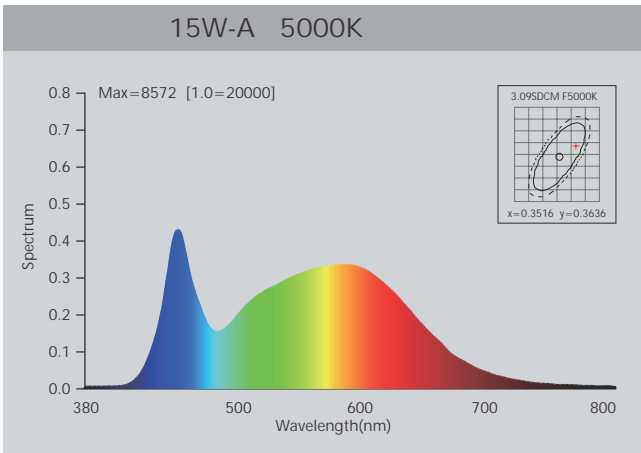
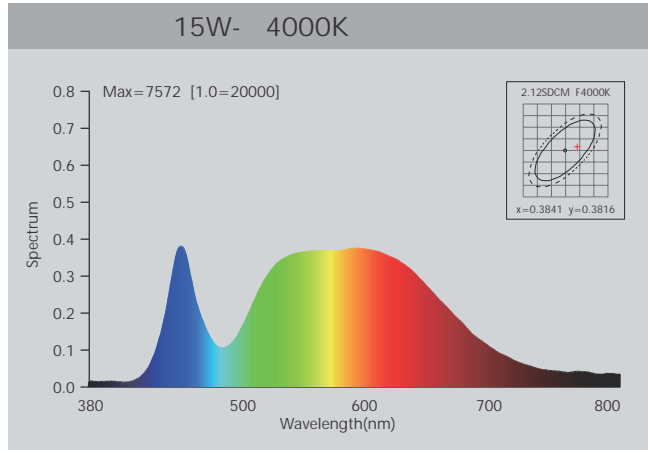
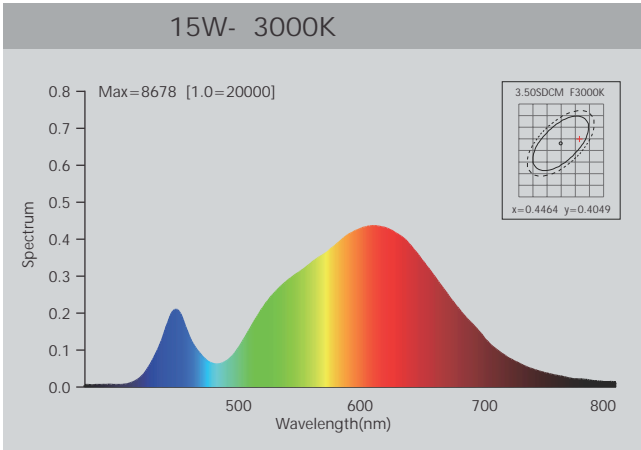

## Photometric Diagram

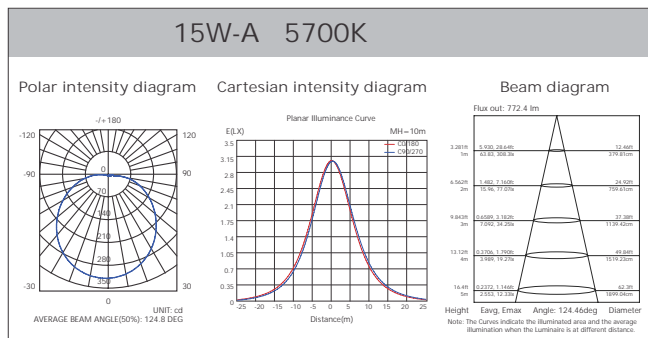
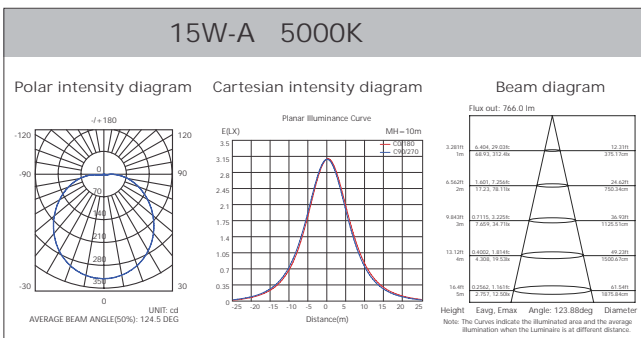
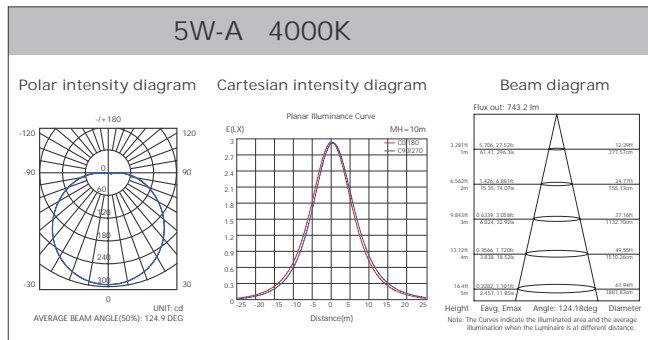
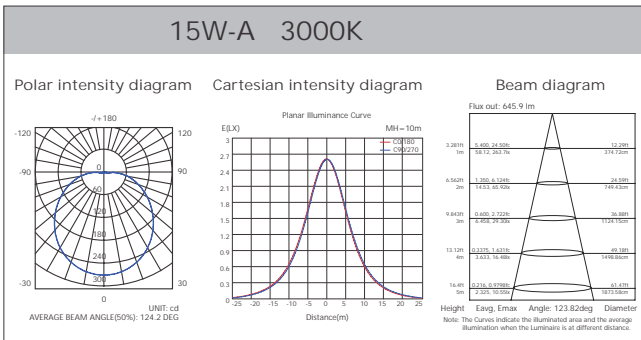

## Polar Diagram Comparison

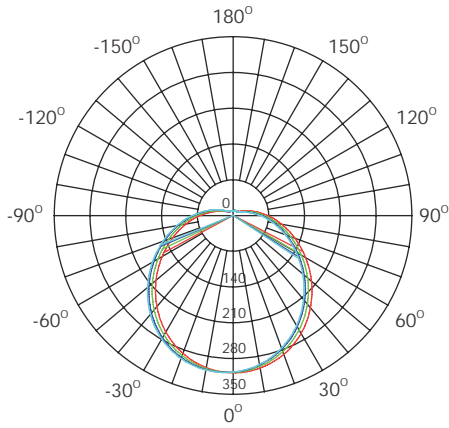

UNIT: cd

- C0/180, 124.8 deg
- C30/210, 124.9 deg
- C60/240, 124.8 deg
- C90/270, 124.6 deg

AVERAGE BEAM ANGLE (50%): 124.8DEG



## Driver lifetime & LED lifetime

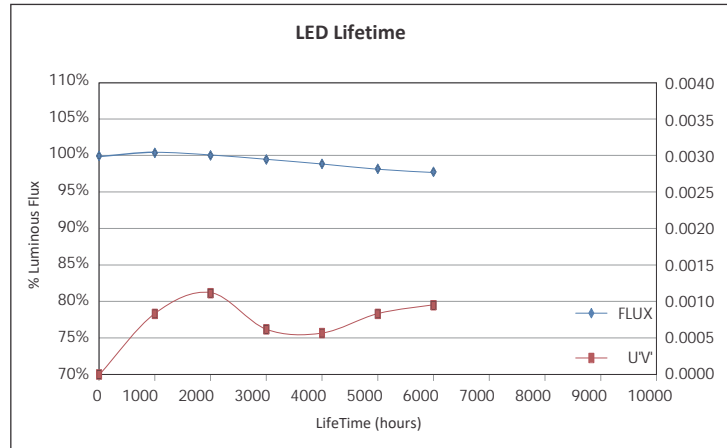
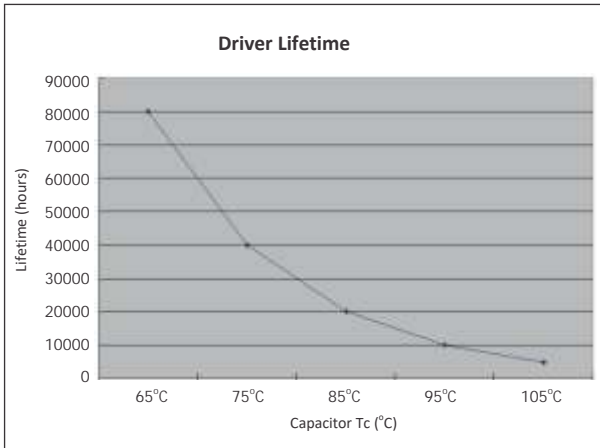

## Temperature

The testing is operated at 35°C environment temperature.

The minimum lifetime for capacitor is 5000hours at 105°C, the lifetime will be double when the temperature drop each 10°C

Under 75°C working TEMP, max 40000hrs life time is achievable.

The highest withstand temperature of IC is 120°C

The highest withstand temperature of MOS is 120°C

The highest withstand LED junction temperature is 120°C

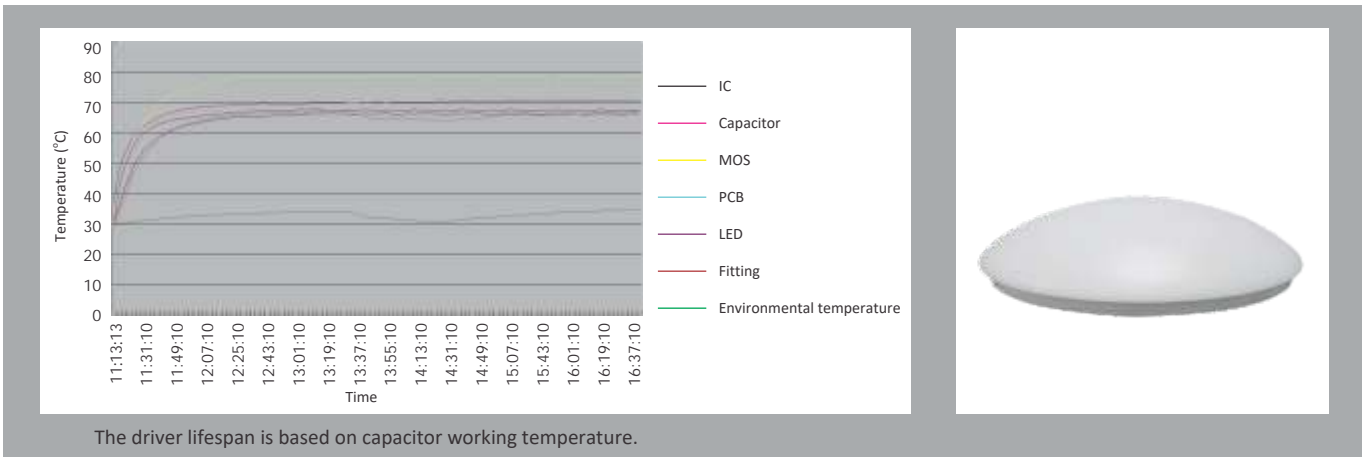

The driver lifespan is based on capacitor working temperature.

15W LED OYSTER DATA SHEET (PLAIN)